

Introduction to

Solid Modeling

Using

SOLIDWORKS®

2018

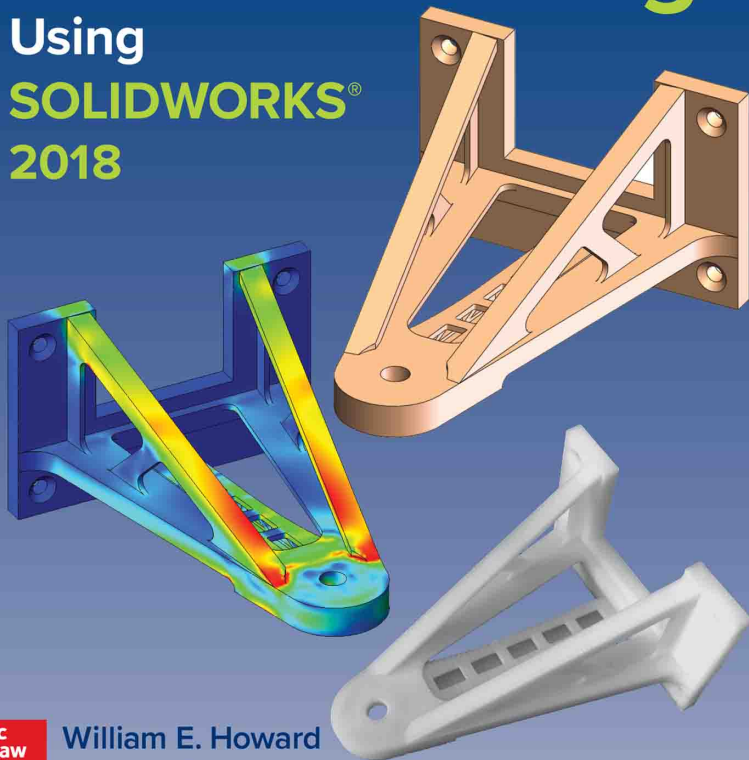

**Mc
Graw
Hill
Education**

William E. Howard
Joseph C. Musto

INTRODUCTION TO
Solid Modeling
Using SOLIDWORKS® 2018

William E. Howard
East Carolina University

Joseph C. Musto
Milwaukee School of Engineering





INTRODUCTION TO SOLID MODELING USING SOLIDWORKS® 2018

Published by McGraw-Hill Education, 2 Penn Plaza, New York, NY 10121. Copyright © 2019 by McGraw-Hill Education. All rights reserved. Printed in the United States of America. Previous editions © 2018, 2017, and 2016. No part of this publication may be reproduced or distributed in any form or by any means, or stored in a database or retrieval system, without the prior written consent of McGraw-Hill Education, including, but not limited to, in any network or other electronic storage or transmission, or broadcast for distance learning.

Some ancillaries, including electronic and print components, may not be available to customers outside the United States.

This book is printed on acid-free paper.

1 2 3 4 5 6 7 8 9 QVS 22 21 20 19 18

ISBN 978-1-259-82017-5

MHID 1-259-82017-3

Senior Portfolio Manager: *Thomas M. Scaife, Ph.D.*

Product Developer: *Heather Ervolino*

Marketing Manager: *Shannon O'Donnell*

Content Project Manager: *Jeni McAtee*

Buyer: *Susan K. Culbertson*

Design: *Debra Kubiak*

Content Licensing Specialist: *Lorraine Buczek*

Cover Image: *William E. Howard*

Compositor: *Fleck's Communications, Inc.*

The Internet addresses listed in the text were accurate at the time of publication. The inclusion of a website does not indicate an endorsement by the authors or McGraw-Hill Education, and McGraw-Hill Education does not guarantee the accuracy of the information presented at these sites.

mheducation.com/highered

About the Authors

Ed Howard is an Associate Professor in the Department of Engineering at East Carolina University, where he teaches classes in solid modeling, engineering computations, solid mechanics, and composite materials. Prior to joining ECU, Ed taught at Milwaukee School of Engineering. He holds a B.S. in Civil Engineering and an M.S. in Engineering Mechanics from Virginia Tech, and a Ph.D. in Mechanical Engineering from Marquette University.

Ed worked in design, analysis, and project engineering for 14 years before beginning his academic career. He worked for Thiokol Corporation in Brigham City, UT; Spaulding Composites Company in Smyrna, TN, and Sta-Rite Industries in Delavan, WI. He is a registered Professional Engineer in Wisconsin.

Joe Musto is a Professor in the Mechanical Engineering Department at Milwaukee School of Engineering, where he teaches in the areas of machine design, solid modeling, and numerical methods. He holds a B.S. degree from Clarkson University, and both an M.Eng. and Ph.D. from Rensselaer Polytechnic Institute, all in mechanical engineering. He is a registered Professional Engineer in Wisconsin.

Prior to joining the faculty at Milwaukee School of Engineering, he held industrial positions with Brady Corporation (Milwaukee, WI) and Eastman Kodak Company (Rochester, NY). He has been using and teaching solid modeling using SOLIDWORKS since 1998.

Joe and Ed, together with Rick Williams of Auburn University, are the authors of *Engineering Computations: An Introduction using MatLab® and Excel®*, part of the McGraw-Hill “Best” Series.

This page intentionally left blank

CONTENTS

Special Features vii
Preface ix

PART ONE

Learning SOLIDWORKS® I

1 Basic Part Modeling Techniques 3

- 1.1 Engineering Design and Solid Modeling 4
- 1.2 Part Modeling Tutorial: Flange 5
- 1.3 Modifying the Flange 25
- 1.4 Using Dimensions and Sketch Relations 30
- 1.5 A Part Created with Revolved Geometry 35
Problems 49

2 Engineering Drawings 55

- 2.1 Drawing Tutorial 55
- 2.2 Creating a Drawing Sheet Format 70
- 2.3 Creating an eDrawing 76
Problems 80

3 Additional Part Modeling Techniques 83

- 3.1 Part Modeling Tutorial: Wide-Flange Beam Section 84
- 3.2 Part Modeling Tutorial: Bracket 92
- 3.3 Sharing and Displaying the Solid Model 106
Problems 111

4 Advanced Part Modeling 117

- 4.1 A Lofted and Shelled Part 117
- 4.2 Parts Created with Swept Geometry 127
- 4.3 A Part Created with a 3-D Sketch as the Sweep Path 131
Problems 138

5 Parametric Modeling Techniques 147

- 5.1 Modeling Tutorial: Molded Flange 148
- 5.2 Creation of Parametric Equations 161
- 5.3 Modeling Tutorial: Cap Screw with Design Table 165
- 5.4 Incorporating a Design Table in a Drawing 172
Problems 179

6 Creation of Assembly Models 189

- 6.1 Creating the Part Models 190
- 6.2 Creating an Assembly of Parts 195
- 6.3 Adding Features at the Assembly Level 204
- 6.4 Adding Fasteners to the Assembly 207
- 6.5 Creating an Exploded View 211
Problems 217

- 7** Advanced Assembly Operations 227
 - 7.1 Creating the Part Models 227
 - 7.2 Creating a Complex Assembly of Subassemblies and Parts 228
 - 7.3 Detecting Interferences and Collisions 234 Problems 236

- 8** Assembly Drawings 239
 - 8.1 Creating an Assembly Drawing 239
 - 8.2 Adding an Exploded View 241
 - 8.3 Creating a Bill of Materials 244 Problems 248

PART TWO

Applications of SOLIDWORKS® 251

- 9** Generation of 2-D Layouts 253
 - 9.1 A Simple Floor Plan Layout 253
 - 9.2 Finding the Properties of 2-D Shapes 266 Problems 271

- 10** Solution of Vector Problems 275
 - 10.1 Vector Addition 275
 - 10.2 Vector Addition with SOLIDWORKS 276
 - 10.3 Modifying the Vector Addition Drawing 278
 - 10.4 Further Solution of Vector Equations 281
 - 10.5 Kinematic Sketch of a Simple Mechanism 284 Problems 291

- 11** Analysis of Mechanisms 295
 - 11.1 Approaching Mechanism Design with SOLIDWORKS Assemblies 296
 - 11.2 Development of Part Models of Links 297
 - 11.3 Development of the Assembly Model of the Four-Bar Linkage 300

- 11.4 Creating Simulations and Animation with a Motion Study 304
- 11.5 Investigating Mechanism Design Problems 313

- 12** Design of Molds and Sheet Metal Parts 323
 - 12.1 A Simple Two-Part Mold 323
 - 12.2 A Core-and-Cavity Mold 328
 - 12.3 A Sheet Metal Part 336 Problems 345

- 13** The Use of SOLIDWORKS to Accelerate the Product Development Cycle 349
 - 13.1 3-D Printing 350
 - 13.2 Finite Element Analysis 359
 - 13.3 Product Data Management 361
 - 13.4 Some Final Thoughts 364

APPENDIX

- A** Recommended Settings 365
 - A.1 System Settings 365
 - A.2 Part Settings 367
 - A.3 Drawing Settings 372
 - A.4 Assembly Settings 374
 - A.5 Backing Up and Transferring Settings 375
 - A.6 Summary of Recommended Settings 378

- B** The SOLIDWORKS Interface: Use and Customization 379

Index 393

SPECIAL FEATURES

DESIGN INTENT

- Planning the Model 19
- Selecting a Modeling Technique 24
- Planning for Other Uses of the Model 40
- Choosing the Initial Sketch Plane 42
- Keeping It Simple 46
- Exploiting Associativity 62
- Symmetry in Modeling 104
- Planning an Assembly Model 197
- Part-Level and Assembly-Level Features 207
- Manufacturing Considerations 213
- Assembly-Level Dimensions 242

FUTURE STUDY

- Dynamics (Kinetics) 47
- Manufacturing Processes, Geometric Dimensioning and Tolerancing, and Metrology 67
- Industrial Design 126
- Industrial Engineering 265
- Mechanics of Materials 269
- Machine Dynamics and Machine Design 309
- Materials and Processes 335

This page intentionally left blank

PREFACE

As design engineers and engineering professors, the authors have witnessed incredible changes in the way that products are designed and manufactured. One of the biggest changes over the past 30 years has been the development and widespread usage of solid modeling software. When we first saw solid modeling, it was used only by large companies. The cost of the software and the powerful computer workstations required to run it, along with the complexity of using the software, limited its use. As the cost of computing hardware dropped, solid modeling software was developed for personal computers. In 1995, the SOLIDWORKS® Corporation released the initial version of SOLIDWORKS® software, the first solid modeling program written for the Microsoft Windows operating system. Since then, the use of solid modeling has become an indispensable tool for almost any company, large or small, that designs a product.

Two applications of solid modeling in the design process, additive manufacturing and finite element analysis, are illustrated on the cover of this book. The SOLIDWORKS model of a bracket design can be saved to a file format that can be used by one of the many types of additive manufacturing machines (commonly referred to as 3-D printers) to make a physical prototype of the bracket. The prototype can be used to verify fit with other parts or tested for functionality. The SOLIDWORKS model can also be analyzed with finite element analysis (FEA) to examine the stresses that the part will experience when loads are applied. The plot on the cover shows the highest-stressed regions in red and lower-stressed regions in other colors of the spectrum. Both physical prototypes and the “virtual” prototypes of FEA allow designers to make changes early in the design process. Additive manufacturing and FEA are discussed further in Chapter 13.

SOLIDWORKS is a registered trademark of Dassault Systèmes SolidWorks Corporation.

Motivation for This Text

When we saw a demonstration of the SOLIDWORKS software in 1998, we were both instantly hooked. Not only was the utility of the software obvious, but the program was easy to learn and fun to use. Since then, we have shared our enthusiasm with the program with hundreds of students in classes at Milwaukee School of Engineering and East Carolina University, in summer programs with high school students, and in informal training sessions. Most of the material in this book began as tutorials that we developed for these purposes. We continue to be amazed at how quickly students at all levels can learn the basics of the program, and by the sophisticated projects that many students develop after only a short time using the software.

While anyone desiring to learn the SOLIDWORKS program can use this book, we have added specific elements for beginning engineering students. With these elements, we have attempted to introduce students to the design process and to relate solid modeling to subjects that most engineering students will study later. We hope that the combination of the tutorial style approach to teaching the functionality of the software together with the integration of the material into the overall study of engineering will motivate student interest not only in the SOLIDWORKS software but in the profession of engineering.

Philosophy of This Text

The development of powerful and integrated solid modeling software has continued the evolution of computer-aided design packages from drafting/graphical communication tools to full-fledged engineering design and analysis tools. A solid model is more than simply a drawing of an engineering component; it is a true virtual representation of the part, which can be manipulated, combined with other parts into complex assemblies, used directly for analysis, and used to drive the manufacturing equipment that will be used to produce the part.

This text was developed to exploit this emerging role of solid modeling as an integral part of the engineering design process; while proficiency in the software will be achieved through the exercises provided in the text, the traditional “training” exercises will be augmented with information on the integration of solid modeling into the engineering design process. These topics include:

- The exploitation of the parametric features of a solid model, to not only provide an accurate graphical representation of a part but also to effectively capture an engineer’s design intent,
- The use of solid models as an analysis tool, useful for determining properties of components as well as for virtual prototyping of mechanisms and systems,
- The integration of solid modeling with component manufacturing, including the generation of molds, sheet metal patterns, and rapid prototyping files from component models.

Through the introduction of these topics, students will be shown not only the powerful modeling features of the SOLIDWORKS program, but also the role of the software as a full-fledged integrated engineering design tool.

The Use of This Text

This text primarily consists of chapter-long tutorials, which introduce both basic concepts in solid modeling (such as part modeling, drawing creation, and assembly modeling) and more advanced applications of solid modeling in engineering analysis and design (such as mechanism modeling, mold creation, sheet metal bending, and rapid prototyping). Each tutorial is organized as “keystroke-level” instructions, designed to teach the use of the software.

While these tutorials offer a level of detail appropriate for new professional users, this text was developed to be used as part of an introductory engineering course, taught around the use of solid modeling as an integrated engineering design and analysis tool. Since the intended audience is undergraduate students new to the field of engineering, the text contains features that help to integrate the concepts learned in solid modeling into the overall study of engineering. These features include:

- *Video Examples:* Short video tutorials now accompany multiple chapters. These videos introduce students to the concepts of solid modeling and the SOLIDWORKS commands that they will use in the chapter following the step-by-step tutorials.
- *Design Intent Boxes:* These are intended to augment the “keystroke-level” tutorials to include the rationale behind the sequence of operations chosen to create a model.
- *Future Study Boxes:* These link the material contained in the chapters to topics that will be seen later in the academic and professional careers of new engineering students. They are intended to motivate interest in advanced study in engineering, and to place the material seen in the tutorials within the context of the profession.

While these features are intended to provide additional motivation and context for beginning engineering students, they are self-contained, and may be omitted by professionals who wish to use this text purely for the software tutorials.

New in This Edition

Several chapters now have video examples to introduce that chapter’s content. We have found that many students benefit from seeing an example of what they will be learning (such as placing views within a 2-D drawing or adding mates to an assembly) before attempting the processes themselves.

Additionally, this new edition of the text has been fully updated for the SOLIDWORKS 2018 software package. All tutorials and figures have been modified for the new version of the software.

The Organization of This Text

The organization of the chapters of the book reflects the authors’ preferences in teaching the material, but allows for several different options. We have found that covering drawings early in the course is helpful in that we can have students turn in

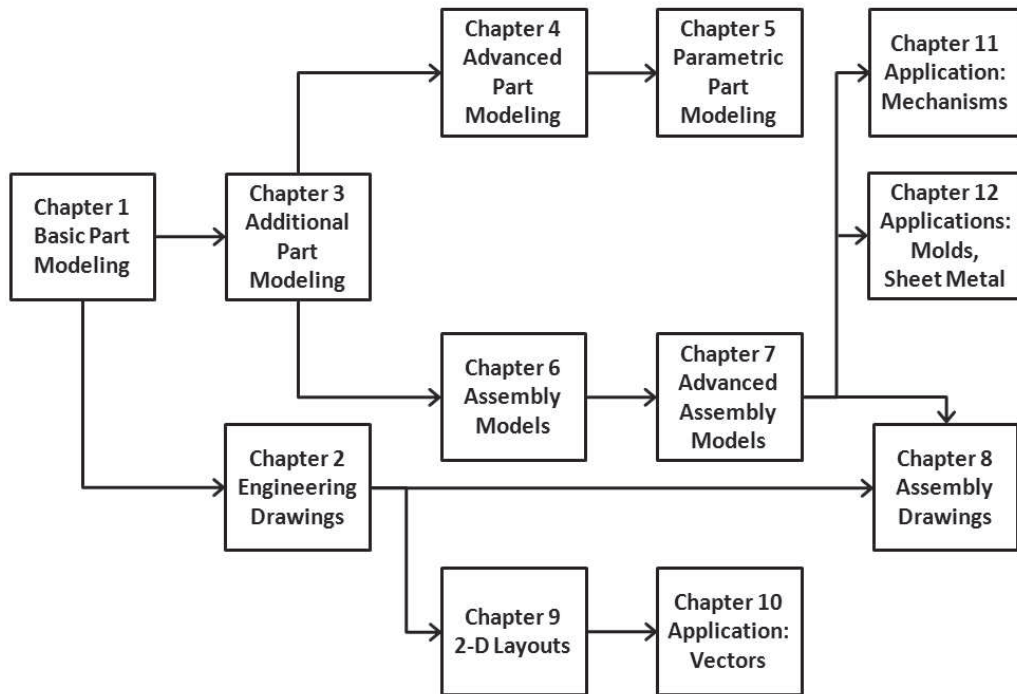

drawings rather than parts as homework assignments. The eDrawings feature, which is covered in Chapter 2, is especially useful in that eDrawings files are small (easy to e-mail), self-contained (not linked to the part file), and can be easily marked up with the editing tools contained in the eDrawings program.

The flowchart above illustrates the relations between chapters, and can be used to map alternative plans for coverage of the material. For example, if it is desired to cover assemblies as soon as possible (as might be desired in a course that includes a project) then the chapters can be covered in the order 1-3-4-6-7-2-8, with the remaining chapters covered in any order desired. An instructor who prefers to cover parts, assemblies, and drawings in that order may cover the chapters in the order 1-3-4-5-6-7-2-8 (skipping section 5.4 until after Chapter 2 is covered), again with the remaining chapters covered in any order.

Chapters 9 and 10 may be omitted in a standard solid modeling course; however, they can be valuable in an introductory engineering course. Engineering students will almost certainly find use at some point for the 2-D layout and vector mechanics applications introduced in these chapters. Chapter 13 is intended to wrap up the course with a discussion of how solid modeling is used as a tool in the product development cycle. Appendix A summarizes the recommended settings to the SOLIDWORKS program that are used throughout the book, while Appendix B shows options for customizing the SOLIDWORKS interface.

Resources for Instructors

Additional resources are available on the web at www.mhhe.com/howard2018. Included on the website are tutorials for three popular SOLIDWORKS Add-Ins: SOLIDWORKS® Simulation, SOLIDWORKS® Motion™, and PhotoView360, the video examples, and the book figures in PowerPoint format. Instructors can also access PowerPoint files for each chapter and model files for all tutorials and end-of-chapter problems as well as a teaching guide (password-protected; contact your McGraw-Hill representative for access).

Acknowledgments

We are grateful to our friends at McGraw-Hill, especially Thomas Scaife and Heather Ervolino, for their support and encouragement during this project. In particular, we offer special thanks to Karen Fleckenstein of Fleck's Communications, Inc. who did the page layouts. Also, thanks to Tim Maruna, who encouraged us to initiate this project.

At SOLIDWORKS Corporation, Marie Planchard has provided continuous support for the project. The authors are also appreciative of the support of our SOLIDWORKS resellers, Computer Aided Technology, Inc. and TriMech Solutions.

We also want to thank the reviewers whose comments have undoubtedly made the book better.

Many of our students and colleagues used early versions of the manuscript and materials that eventually became this text. We thank them for their patience and helpful feedback along the way.

*Ed Howard
Joe Musto*

This page intentionally left blank

PART ONE

Learning SOLIDWORKS®

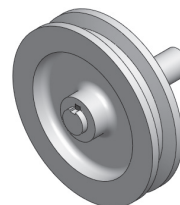
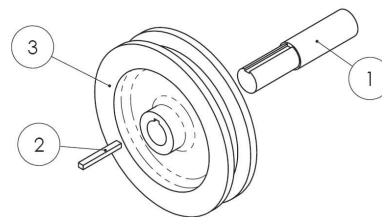
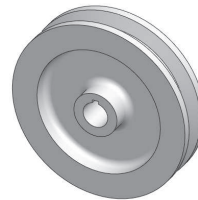
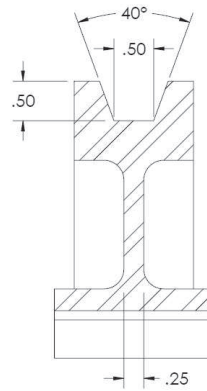

This page intentionally left blank

CHAPTER 1

Basic Part Modeling Techniques

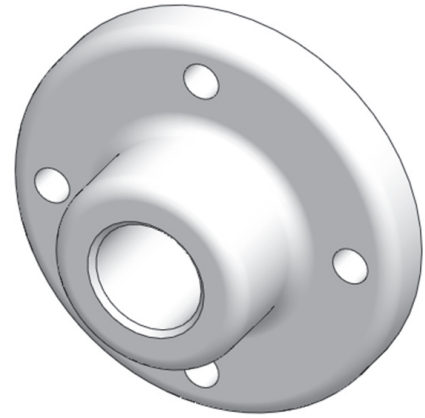

Introduction

Solid modeling has become an essential tool for most companies that design mechanical structures and machines. Just 20 years ago, this would have been hard to imagine. While 3-D modeling software existed, it was very expensive and required high-end computer workstations to run. An investment of \$50,000 or more was required for every workstation with software, not including training of the operator. As a result, only a few industries used solid modeling, and the trained operators tended to work exclusively with the software. The dramatic performance improvements and price drops of computer hardware, along with increased competition among software vendors, have significantly lowered the cost barrier for companies to enter the solid modeling age. The software has also become much easier to use, so that engineers who have many other job functions can use solid modeling when required without needing to become software specialists. The SOLIDWORKS® program was among the first solid modeling programs to be written exclusively for the Microsoft Windows environment. Since its initial release in 1995, it has been adopted by thousands of companies worldwide. This text is laid out as a series of tutorials that cover most of the basic features of the SOLIDWORKS program. Although these tutorials will be of use to anyone desiring to learn the software, they are written primarily for freshmen engineering students. Accordingly, topics in engineering design are introduced along the way. “Future Study” boxes give a preview of coursework that engineering students will encounter later, and relate that coursework to the solid modeling tutorials. In this first chapter, we will learn how to make two simple parts with SOLIDWORKS software.

Chapter Objectives

In this chapter, you will:

- be introduced to the role of solid modeling in engineering design,
- learn how to create 2-D sketches and create 3-D extruded and revolved geometry from these sketches,
- use dimensions and relations to define the geometry of 2-D sketches,
- add fillets, chamfers, and circular patterns of features to part models,
- learn how to modify part models, and
- define the material and find the mass properties of part models.

1.1 Engineering Design and Solid Modeling

The term *design* is used to describe many endeavors. A clothing designer creates new styles of apparel. An industrial designer creates the overall look and function of consumer products. Many design functions concentrate mainly on aesthetic considerations—how the product looks, and how it will be accepted in the marketplace. The term *engineering design* is applied to a process in which fundamentals of math and science are applied to the creation or modification of a product to meet a set of objectives.

Engineering design is only one part of the creation of a new product. Consider a company making consumer products, for example bicycles. A marketing department determines the likely customer acceptance of a new bike model and outlines the requirements for the new design. Industrial designers work on the preliminary design of the bike to produce a design that combines functionality and styling that customers will like. Manufacturing engineers must consider how the components of the product are made and assembled. A purchasing department will determine if some components will be more economical to buy than to make. Stress analysts will predict whether the bike will survive the forces and environment that it will experience in service. A model shop may need to build a physical prototype for marketing use or to test functionality.

During the years immediately following World War II, most American companies performed the tasks described above more or less sequentially. That is, the design engineer did not get involved in the process until the specifications were completed, the manufacturing engineers started once the design was finalized, and so on. From the 1970s through the 1990s, the concept of *concurrent engineering* became widespread. Concurrent engineering refers to the process in which engineering tasks are performed simultaneously rather than sequentially. The primary benefits of concurrent engineering are shorter product development times and lower development costs. The challenges of implementing concurrent engineering are mostly in communications—engineering groups must be continuously informed of the actions of the other groups.

Solid modeling is an important tool in concurrent engineering in that the various engineering groups work from a common database: the solid model. In a 2-D CAD (Computer-Aided Design) environment, the design engineer produced sketches of the component, and a draftsman produced 2-D design drawings. These drawings were forwarded to the other engineering organizations, where much of the information was then duplicated. For example, a toolmaker created a tool design from scratch, using the drawings as the basis. A stress analyst created a finite element model, again starting from scratch. A model builder created a physical prototype by hand from the drawing parameters. With a solid model, the tool, finite element model, and rapid prototype model are all created directly from the solid model file. In addition to the time savings of avoiding the steps of recreating the design for the various functions, many errors are avoided by having everyone working from a common database. Although 2-D drawings are usually still required, since they are the best way to document dimensions and tolerances, they are linked directly to the solid model and are easy to update as the solid model is changed.

A mechanical engineering system (assembly) may be composed of thousands of components (parts). The detailed design of each component is important to the operation of the system. In this chapter, we will step through the creation of simple components. In future chapters, we will learn how to make 2-D drawings from a part file, and how to put components together in an assembly file.

1.2 Part Modeling Tutorial: Flange

This tutorial will lead you through the creation of a simple solid part. The part, a flange, is shown in **Figure 1.1** and is described by the 2-D drawing in **Figure 1.2**.

FIGURE 1.1

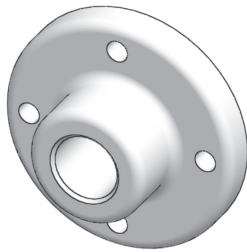
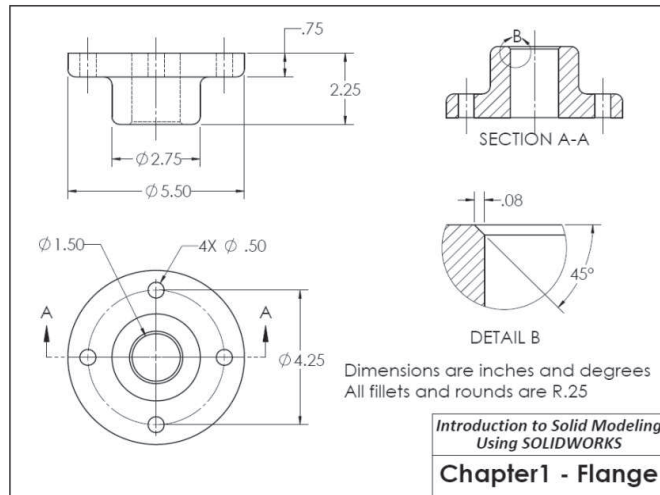

FIGURE 1.2



Begin by double-clicking the SOLIDWORKS icon on your desktop. The Welcome dialog box opens, as shown in Figure 1.3. From this box, we can begin a new document (part, assembly, or drawing) or select a recently-opened document. Click Part from the New group. If the Units and Dimension Standard box appears, as shown in Figure 1.4, select “IPS” as the units and “ANSI” as the standard. Click OK.

FIGURE 1.3

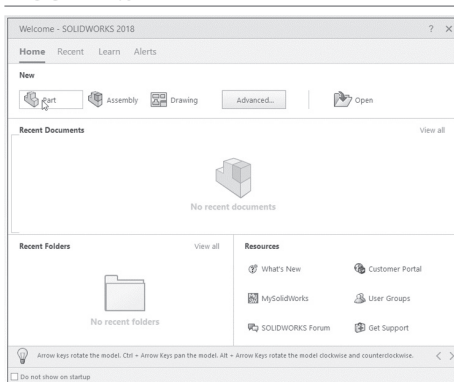
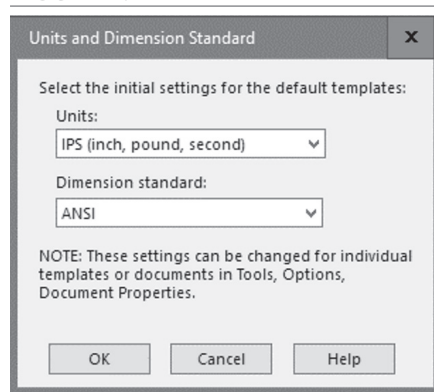

FIGURE 1.4



VIDEO EXAMPLE I

In this chapter, we begin by making and dimensioning 2-D sketches and then creating 3-D features from extrusions of the sketches.

Creation of the simple part shown here, with the dimensions as shown in the drawing to the right, is demonstrated in a video at www.mhhe.com/howard2018. (We will learn to make drawings from 3-D parts in Chapter 2.)

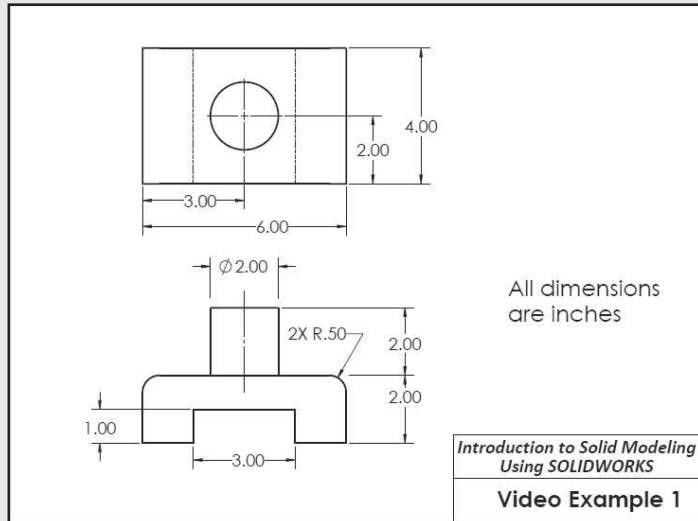
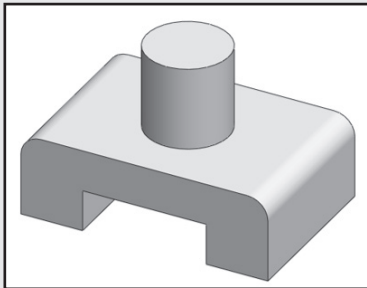

The Units and Dimension Standard box only appears the first time SOLIDWORKS is opened. The selections become the default values for all new files. In this chapter, we will see how to set these values for individual files and to change the default values.

Note that you can return to the Welcome dialog at any point by selecting the icon shown in Figure 1.5.

FIGURE 1.5

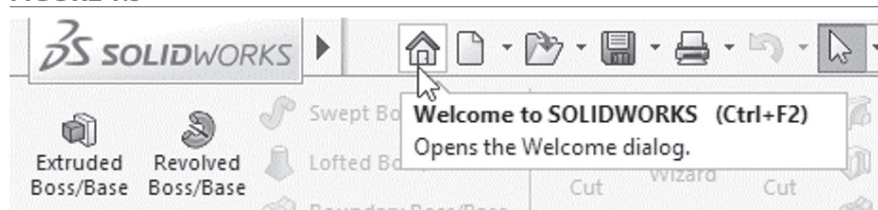

Before we begin modeling the flange, we will establish a consistent setup of the SOLIDWORKS environment. The default screen layout is shown in **Figure 1.6**. The graphics area occupies most of the screen. The part, drawing, or assembly will be displayed in this area. At the top of the screen is the Menu Bar, which contains the Main Menu and a toolbar with several commonly-used tools such as Save, Print, and Redo. Note that if you pass the cursor over the SOLIDWORKS button in the Menu Bar, the Main Menu will “fly out,” or be temporarily displayed, as shown in **Figure 1.7**. The fly-out feature is designed to save room on the screen. However, since we will be using the menu often, we will disable the fly-out so that the menu is always displayed.

Move the cursor over the SOLIDWORKS button to display the menu. Click on the pushpin icon at the right side of the menu, as shown in **Figure 1.8, to lock the display of the menu.**

FIGURE 1.6

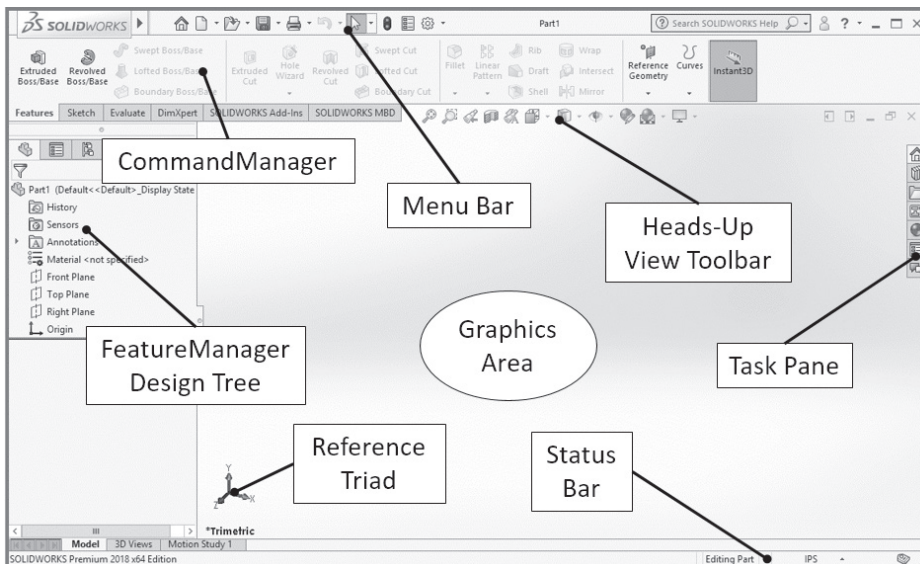
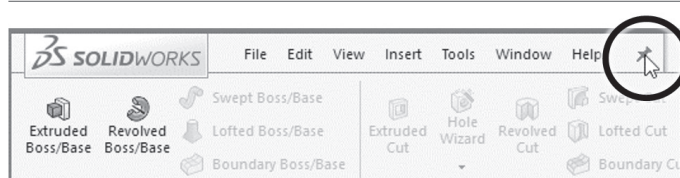

FIGURE 1.7



FIGURE 1.8



The CommandManager contains most of the tools that you will use to create parts. When working in the part mode, there are two categories of tools that we will use extensively: Sketch tools used in creating 2-D sketches, and Features tools used to create and modify 3-D features. Clicking on the Sketch and Features tabs at the bottom of the CommandManager, as shown in **Figure 1.9**, changes the tools on the CommandManager to those of the selected group. By default, there are several other groups available besides the Sketch and Features groups. To simplify the interface, we will hide these groups for now.

FIGURE 1.9



FIGURE I.10

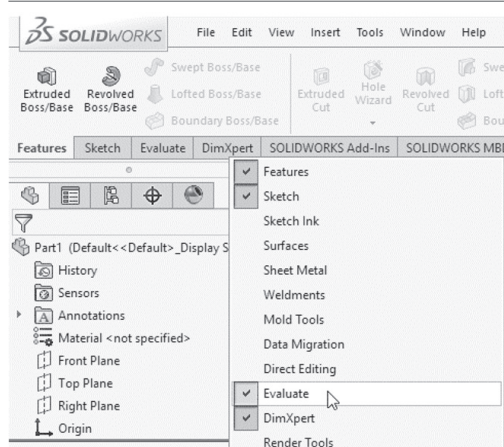

Right-click on one of the CommandManager tabs. A list of available groups is displayed, with a check mark shown beside each active group (Figure I.10). Click on any of the active groups other than Features and Sketch. This will clear the check mark and turn off the display of that group. Repeat until only the Features and Sketch groups remain active.

At the right side of the screen is the Task Pane. The Task Pane is a fly-out interface for accessing files and online resources. We will not use the Task Pane that often, but since it takes up very little room in its normal collapsed state, we will leave it on. If you would like to turn it off completely, select View: User Interface from the Main Menu and click on Task Pane.

FIGURE I.11

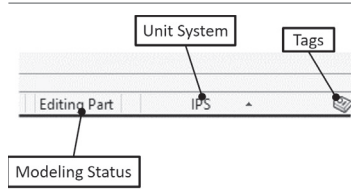

At the bottom of the screen is the Status Bar. When you move the cursor over any toolbar icon or menu command, a message on the left side of the Status Bar describes the command. Other information appears at the right side of the Status Bar, as shown in Figure I.11. The unit system in use is displayed and can be changed directly from the Status Bar. Another feature, called Tags, allows keywords to be associated with files and features. We will not be using Tags in this book. Although the display of the Status Bar can be toggled off and on from the View menu, we recommend leaving it on.

FIGURE I.12

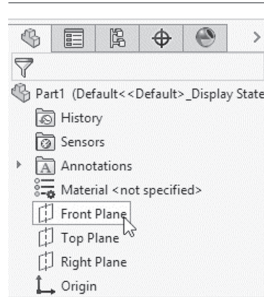

Just to the left of the drawing area is the FeatureManager® Design Tree. The steps that you will execute to create the part will be listed in the FeatureManager. This information is important when the part is to be modified. When you open a new part, the FeatureManager lists an origin and three predefined planes (Front, Top, and Right), as shown in Figure I.12. As you select each plane with your mouse, the plane is highlighted in the graphics area. We can create other planes as needed, and will do so later in this tutorial.

FIGURE I.3

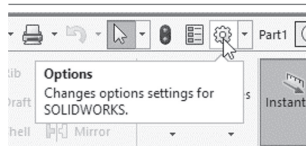

At the top of the graphics area is the Heads-Up View Toolbar. This toolbar contains many options for displaying your model. We will explore these options later in this tutorial.

We will now set some of the program options.

Select the Options Tool from the Menu Bar toolbar, as shown in Figure I.13. (You can also access the options from the Main Menu, by selecting Tools: Options.)

FIGURE I.14

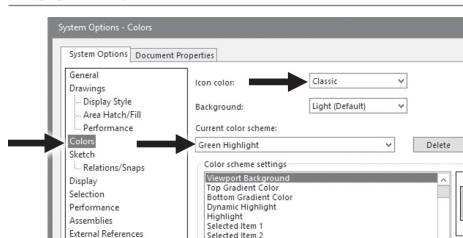

The dialog box contains settings for both the system and for the specific document that is open.

Under the System Options tab, choose Colors and change the icon color to “Classic” and the color scheme to “Green Highlight,” as shown in Figure I.14.

The Classic option for icon colors makes many of the icons display in colors other than the default blue and black, making them easier to recognize for new users. The Green Highlight scheme causes currently selected items to be highlighted in green, as the name implies. The default option is for selected items to be highlighted in light blue. Since another shade of blue is used for other purposes, green highlighting is used in this book to avoid confusion. Since these changes were made to the System Options, they will remain in effect for future SOLIDWORKS sessions. The changes below, which will be made to the Document Properties, will apply only to the current part model.

Select the Document Properties tab. In the list of options, Drafting Standard will be highlighted. Select ANSI from the pull-down menu, as shown in Figure 1.15.

FIGURE 1.15

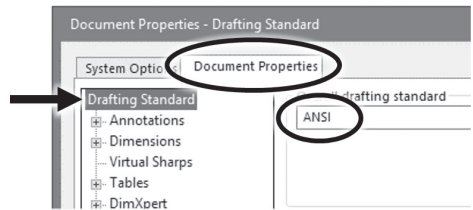

ANSI is the American National Standards Institute, an organization that formulates and publishes the standard drawing practices used by most companies in the United States. European companies are more likely to use the standards of ISO, the International Organization for Standardization.

FIGURE 1.16

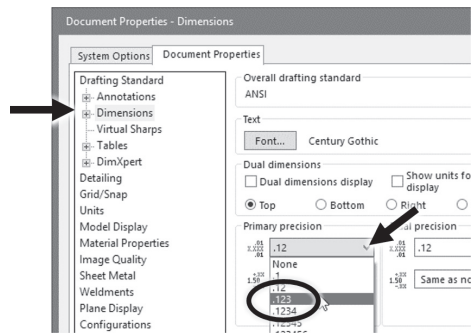

Also under the Document Properties tab, select Dimensions. Use the pull-down menu by the Primary precision box to set the number of decimal places to 3 (.123), as shown in Figure 1.16. (Ignore the message that the drafting standard has been changed to “ANSI-MODIFIED.”) Select Grid/Snap and check the box labeled “Display Grid,” as shown in Figure 1.17. Also, select Units and set the unit system to IPS (inches, pounds, and seconds), the primary length precision to .123 and the precision for angles to None, as shown in Figure 1.18.

FIGURE 1.17

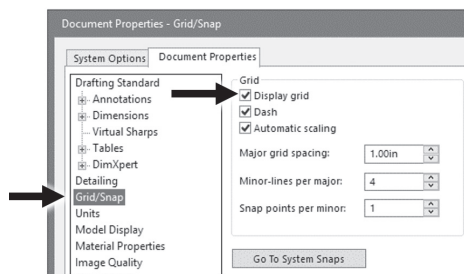
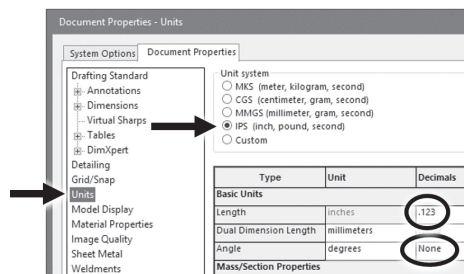

FIGURE 1.18



Note that there are “Dual Dimension” units that can be set in the Units options. For some drawings, you may want to show dimensions in both US units (inches) and SI units (millimeters). Since we will not use dual dimensions for this part, it is not necessary to change the default settings. Also note that we have set the decimal display to .123 in two separate locations. The display of decimal places can be changed at either location.

Click OK to close the dialog box.